

MST RETROFIT PACKAGE P.N. 8033902

The MST, Inc. Model 5700 Carbon Monoxide (CO) Monitor and Alarm is a side mounted, battery powered unit. The monitor has been designed, and is certified by the Canadian Standards Association (CSA LR-104195) to be INTRINSICALLY SAFE FOR USE IN CLASS 1, DIVISION I, GROUPS A,B,C&D when used with two "9V" alkaline transistor type batteries. Includes 80127 monitor with the necessary parts to mount on an existing Breathing Air Panel

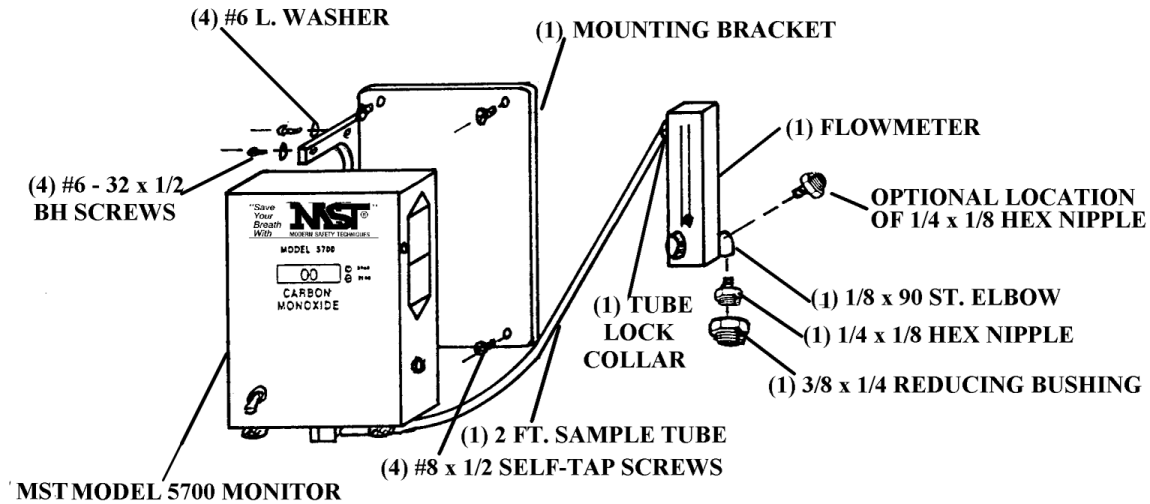

SPECIFICATIONS

RANGE:	0-199 PPM CO
INITIAL ALARM SETTING:	U.S.: 10 PPM CO Canada: 5 PPM CO
DETECTOR TYPE:	ELECTROCHEMICAL CELL
POWER:	9 V ALKALINE BATTERY (Transistor type) - 2 each
BATTERY LIFE:	30 - 35 HOURS

5700 MONITOR

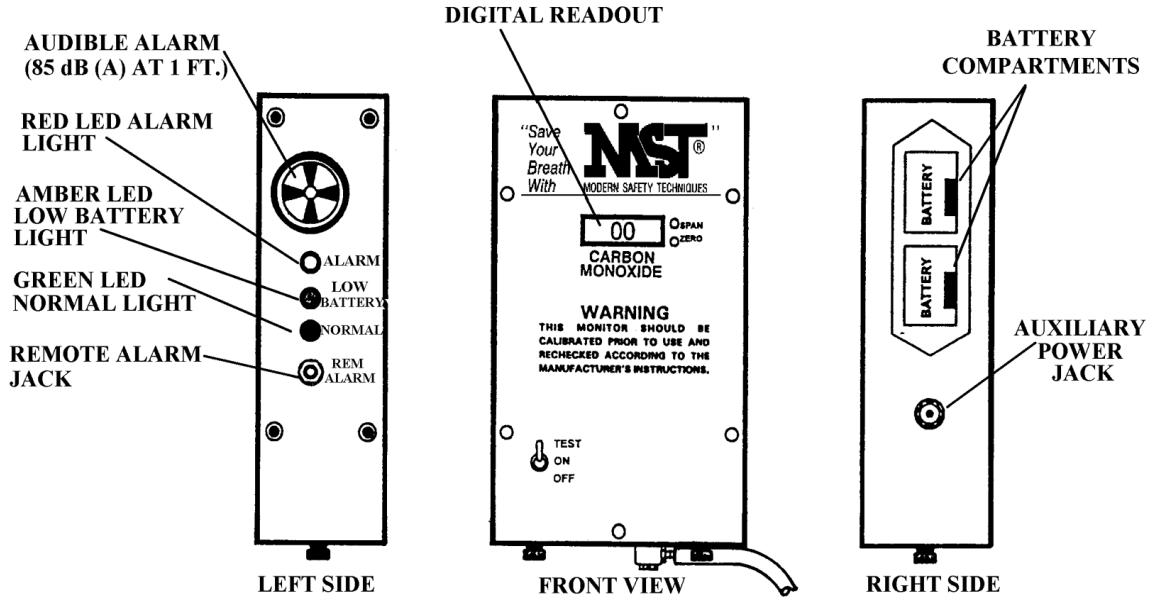

OPTIONAL ACCESSORIES

80133	Replacement Electrochemical CO Sensor
80247	120 VAC Adapter (Voids Intrinsic Safety)
80123	12 VDC Adapter (Voids Intrinsic Safety)
8013501	Rechargeable Battery System (Voids Intrinsic Safety)
8008403	Remote External Alarm (Voids Intrinsic Safety)
8008503	Remote External Strobe (Voids Intrinsic Safety)
80326	Y-Jack for Connecting Remote External Alarm and Strobe to Monitor (Voids Intrinsic Safety)
8039601	Air Horn Alarm System (Voids Intrinsic Safety)
8003102	Large Calibration Kit for Monitor
8003101	Small Calibration Kit for Monitor

MST RETROFIT PACKAGE, P.N. 8033902 MOUNTING INSTRUCTIONS

INSTALL THE MOUNTING BRACKET ON EXISTING PANEL,
OR IN CLOSE PROXIMITY, USING THE (4) #8 SELF - TAP
SCREWS. THEN INSTALL MONITOR TO MOUNTING BRACKET
USING THE (4) #6 BH SCREWS AND LOCK WASHERS.

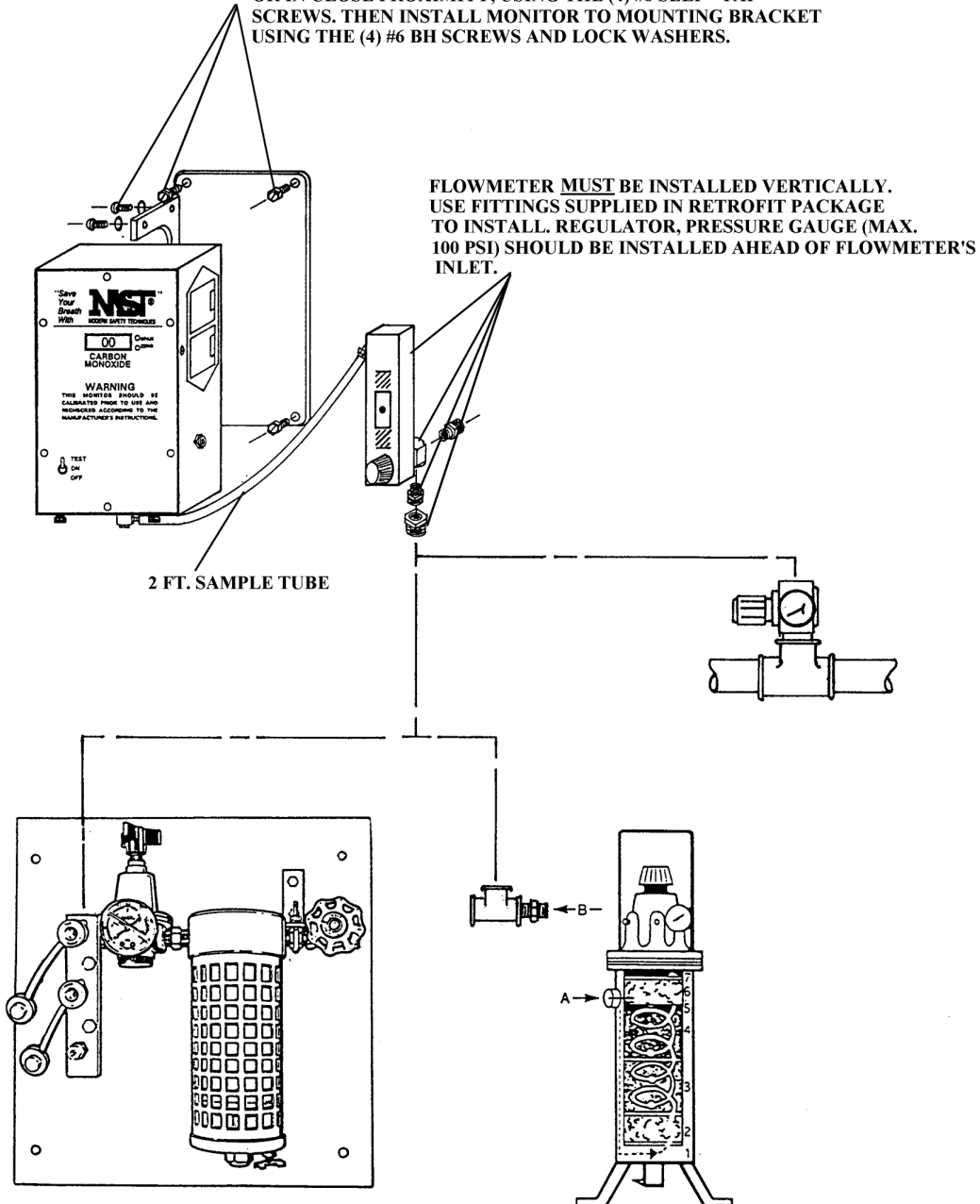

MST RETROFIT PACKAGE, P.N. 8033902 OPERATION INSTRUCTIONS AFTER INSTALLED

